



Huegin-Trietex GmbH
Dammstraße 5a
79588 Efringen-Kirchen
Germany

Phone +49 7628 9100 0
Fax +49 7628 9100 40
info@huegin-trietex.com
www.trietex.com



Specifications:

Rail

Width: 44mm, height: 31mm
made of extruded aluminium AlMgSi 0,5
F22 available in white, black or anodized
EV1.

Runners

Typically S9 runners with built-in slip
clutch, transparent, high-tensile Polycar-
bonate material, exchangeable without
dismounting rail. Also available with
exchangeable stainless steel hooks. Other
runners on request.

Control Options

Chain/Cord Control

Tilting of the louvres by means of laterally
fixed endless plastic bead chain via
reduction gear, traversing of the one-part
or split blind by cordpull.

Wand Control

Specially designed carrier which allows
traversing the slats by pulling but also
tilting by rotating the wand. Eyelet for
connecting the wand can flexibly move
forward and backward.

Motor Control

Silent tilting and traversing by using two
independent aluminium rods. Transport in
90 degree position possible.

Mounting

Ceiling/niche mounting with screws
through the rail or by fixation clips;
wall mounting by adjustable mounting
brackets.

Technical data are subject to change.

Star Plus

Next Generation Vertical Blind.



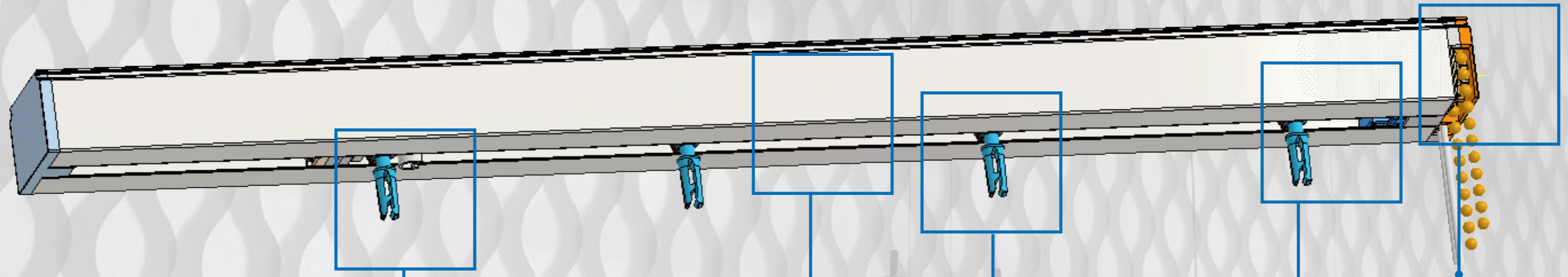

Special double hooks available for sheer/curtain solutions. Fabrics can be easily taken off from the hook.

Rigid 30mm high Aluminium rail. Available in colours black, white and anodized

Chain/Cord operator on left or right side of the rail. Smooth and silent operation. Available in grey, black, white.

Window cleaning function. Stack can be disconnected and moved freely on the rail.

Different runners available. Standard is S9 Type with exchangeable hooks and a width of 9mm. Also available with stainless steel exchangeable hooks and all Star 11mm runners.

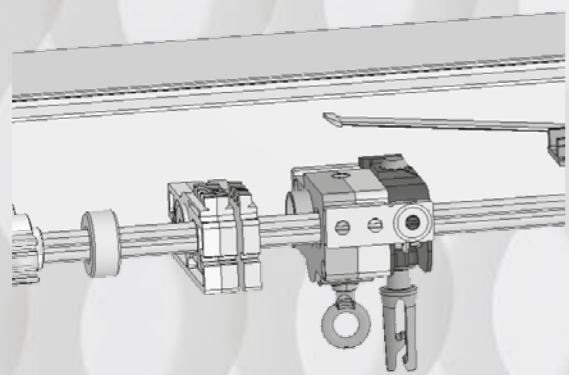

Also available for wand operator for pulling and tilting of blinds. In combination with bottom weights without connecting chain delivers a fully child safe solution.



New: Motorization with a height of only 30mm that can be fully concealed by the rail. Silent operation with two independent rods for tilting and traversing. Available with external 24V power supply and remote control.

The new Star Plus is an extremely versatile vertical blind system without compromises on quality. A rigid aluminium rail with an extensive choice of proven runners is the basis for reliable operation. Rails can be assembled highly efficient with special stoppers for the shaft supports and minimum assembling times. Automation solutions are available on request.